

P.C.B LAYOUT
TOP VIEW

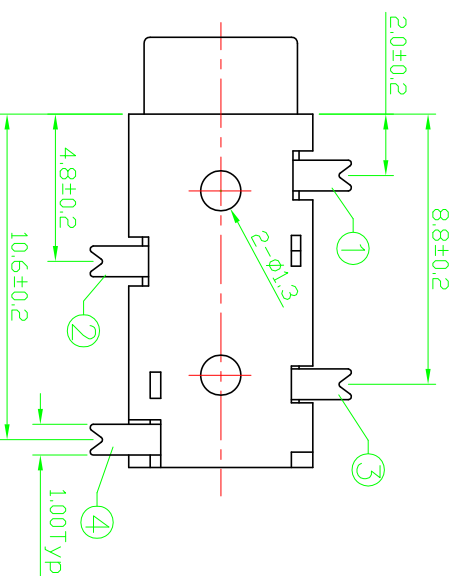

SCHEMATIC

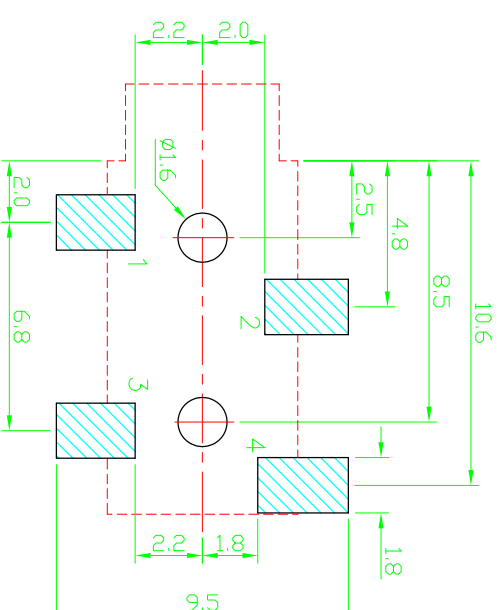
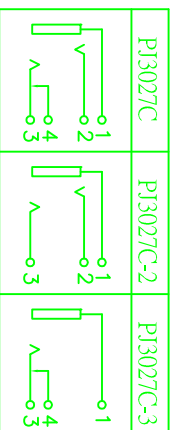

SPECIFICATION

1. Rating : DC 30V 0.5A
2. Contact resistance : $\leq 0.03\Omega$
3. Insulation resistance : $\geq 100M\Omega$ (DC250V)
4. Withstand voltage : 500VAC
5. Insertion and extraction force : 3-20N
6. life test : 8,000 cycles

5	HOUSING	1	PAGT Class	
4	CURVE PIECE	1	BRASS	Ag-Plating
3	SPRING	1	Be-Cu	Ag-Plating
2	CONTACT FOOT	1	PHOSPHOR BRONZE	Ag-Plating
1	CONTACT FOOT	1	PHOSPHOR BRONZE	Ag-Plating
NO.	DESCRIPTION	QTY	MATERIAL	PLATING

UNIT: MM

TYPE: PHONE JACK

MODEL NO: PJ3027C-X

PAPER NO: A4

PAGE 1 OF 1

DESIGNER BY:

CHECK BY:

APPROVED BY:

SCALE

VER

UNLESS OTHERWISE SPECIFIED DIMENSIONS ARE

±0.30

±0.20

±0.10

±3.0°

°

°

°

°

°

°

°

°

°

°

°

°

°

°

°

°

°

°

°

°

°

°

°

°

°

°

°

°

°

°

承永實業有限公司
BLUE SOURCES ELECTRONICS CO.,LTD.