

P.C.B LAYOUT
TOP VIEW

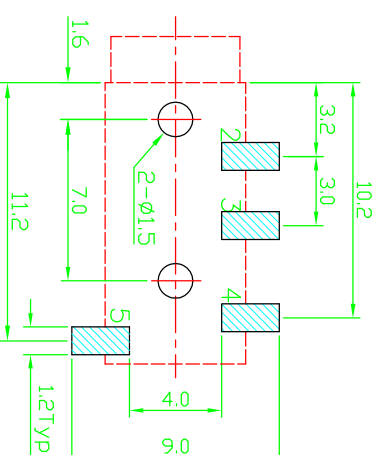

SCHEMATIC

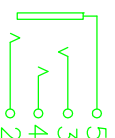

- SPECIFICATION
1. Rating : DC 30V 0.5A
 2. Contact resistance : $\leq 0.03\Omega$
 3. Insulation resistance : $\geq 100M\Omega$ (DC250V)
 4. Withstand voltage : 500VAC
 5. Insertion and extraction force : 3-20N
 6. Life test : 5,000 cycles

NO.	DESCRIPTION	QTY	MATERIAL	PLATING
5	4#CONTACT FOOT	1	PHOSPHOR BRONZE	Ag/Au-Plating
4	3#CONTACT FOOT	1	PHOSPHOR BRONZE	Ag/Au-Plating
3	2#CONTACT FOOT	1	PHOSPHOR BRONZE	Ag/Au-Plating
2	1#CONTACT FOOT	1	PHOSPHOR BRONZE	Ag/Au-Plating
1	HOUSING	1	PA9T	

UNIT: MM	TYPE:	MODEL NO:	PAPER NO: A4	PAGE 1 OF 1
	PHONE JACK	PJ3020D		SCALE VER
				3.1 1

DESIGNER BY:	CHECK BY:	APPROVED BY:

UNLESS OTHERWISE SPECIFIED DIMENSIONS ARE IN MILLIMETERS

.X ±0.30
 .XX ±0.20
 .XXX ±0.10
 .X° ±3.0°
 .XX° ±2.0°
 .XXX° ±1.0°